

CROSS SMART SENSOR

UL7-I INTEGRAL ULTRASONIC LEVEL METER

DIGITAL TECHNOLOGY FOR OPTIMIZED MEASURES



GENERAL

The UL7 series use ultrasonic technology to provide a non-contact method of detecting level measurements.

This versatility makes them deal for a variety of applications. Ultrasonic sensors are not affected by target surface, color or translucency and they function extremely well in harsh environments.

When monitoring liquids, they are not affected by changes in dielectric constant, specific gravity or viscosity. The meters are reliable, user adjustable and require little or no maintenance.

The UL7-I series are loop powered with 4-20mA analogue output.

FEATURES & BENEFITS

- Automatic temperature compensation
- Blind Zone adjustable
- Programmable power of the transducer to suit different applications
- PVDF Sensor Face for chemically aggressive environments

APPLICATIONS

- Water & Waste Water Treat Plant
- Storage Tank Levels
- Effluent pits
- Reservoir Level
- Buffer Tanks
- Open Channel Flow

SPECIFICATIONS

Range	33ft. (10m) std. Optional 10ft. (3 m) for small range application
Accurate	±0.25%FS
Resolution	0.04 in (1 mm)
Angle	10° ± 2°
Blind Zone	12" (0.3m) @ 33ft
Temp. compensation	Automatic
Respond Time	0.5s
Operate Temp.	-40 to 158°F (-40 to 70°C)
Display	4 Digital LCD
Pressure	2bar
Material	Housing: Aluminum die casting; Sensor: PVDF
Process Connection	2-1/2" NPT Mounting Threads
Power Supply	20 to 30V DC
Enclosure Rating	NEMA 4X (IP66)
Weight	3.15kg

DIMENSION

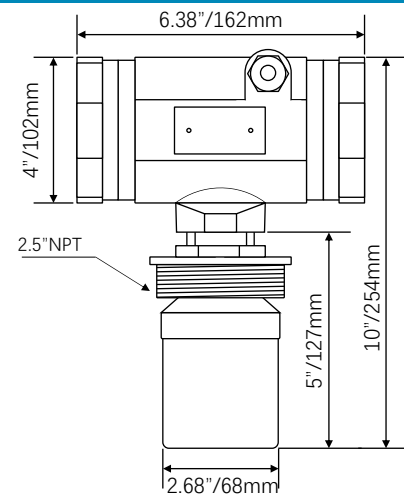

Specifications subject to change without notice.

ORDER CODE

UL7 Smart Ultrasonic Level

-I Integral with LCD display & keypad

Range

03 10' (3 meters)

10 33' (10 meters)

UL7 -I 10



DELTA-PHASE ELECTRONICS, INC.

3 Peters Canyon Rd, Suite 100,
Irvine, CA 92606 U.S.A.
Phone: (949) 701-7728
<http://www.delta-phase.us>

Represented by: